

Performance of Conduction Cooled Splittable Superconducting Magnet Package for Linear Accelerators

V. Kashikhin, N. Andreev, S. Cheban, J. DiMarco, N. Kimura, A. Makarov, Y. Orlov, V. Poloubotko, M. Tartaglia, A. Yamamoto

Abstract— New Linear Superconducting Accelerators need a superconducting magnet package installed inside SCRF Cryomodules to focus and steer electron or proton beams. A superconducting magnet package was designed and built as a collaborative effort of FNAL and KEK. The magnet package includes one quadrupole, and two dipole windings. It has a splittable in the vertical plane configuration, and features for conduction cooling. The magnet was successfully tested at room temperature, in a liquid He bath, and in a conduction cooling experiment. The paper describes the design and test results including: magnet cooling, training, and magnetic measurements by rotational coils. The effects of superconductor and iron yoke magnetization, hysteresis, and fringe fields are discussed.

Index Terms—Accelerator, Cryomodule, Linac, Magnet, Superconducting, Conduction cooling.

I. INTRODUCTION

NEW Linear Superconducting Accelerators need superconducting magnet packages installed inside Cryomodules which are based on the superconducting radio frequency technology (SCRF). In recent years various magnet packages were built and successfully tested for Linear Accelerators. Besides a large International Linear Collider (ILC) [1], there are now a number of smaller linear accelerators [2]-[4] under design and construction: FNAL ASTA and PIP-II, KEK STF, SLAC LCLS-II.

First superconducting magnets for Linear Accelerators were bath cooled by liquid helium (LHe). In recent years there were investigated several conduction cooled magnets for linear accelerators. These magnets did not have a LHe vessel. To avoid the magnet installation in the clean room together with SCRF cavities the magnet package had a splittable in a vertical plane configuration. These magnets could be installed in the cryomodule (see Fig. 1) after the final SCRF cavities string assembly in the clean room. The magnet package is

conductively cooled by pure aluminum channels thermally connected to the LHe supply pipe. The magnet current leads are also conductively cooled and have thermal interceptors at 2 K, 5 K, and 50 K temperature levels (see Fig. 1). The FNAL-KEK collaboration built and successfully tested the first magnet prototype for ILC [9]-[10]. The ILC quadrupole integrated gradient of 36 T is an order of magnitude larger than for other accelerators [2]-[4]. So, an even more compact splittable conduction cooled magnet was built and tested.

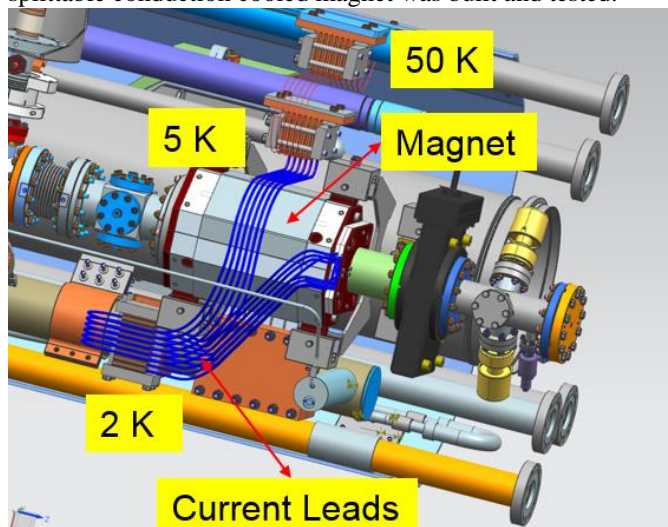

Fig. 1. Magnet package inside the SCRF Cryomodule.

II. MAGNET PACKAGE DESIGN AND FABRICATION

The magnet package design and fabrication is based on the previously built and tested model magnets. It has a splittable in the vertical plane conductively cooled configuration. Besides the easier magnet installation in the cryomodule, the absence of a LHe [5]-[8] vessel allows a more precise magnet alignment to a beam center axis. The magnetic field in the aperture is formed by four iron poles and generated by racetrack type superconducting coils (see Fig. 2). The magnet package parameters for LCLS-II [4] pre-prototype are shown in Table 1. One can see that the peak quadrupole magnet integrated gradient is 2 T, which is 40 times larger than the minimal value of 0.05 T. This means that the magnet at the front end of the accelerator, where the beam energy is low, will work at a very low field, and residual magnetization

Manuscript received October 15, 2015. This work was supported in part by Fermi Research Alliance, LLC, under contract No. DE-AC02-07CH11359 with the U.S. Department of Energy, and in part by the Japan-U.S. cooperative program in High Energy Physics.

V. S. Kashikhin#, N. Andreev, S. Cheban, J. DiMarco, A. Makarov, Y. Orlov, V. Poloubotko, M. Tartaglia are with the Fermi National Accelerator Laboratory, Batavia, IL 60510, USA (corresponding author# phone: 630-840-2899; fax: 630-840-6766; e-mail: kash@fnal.gov).

N. Kimura, A. Yamamoto are with KEK, Japan.

effects should be taken into account. The magnet package includes three windings: the quadrupole, vertical and horizontal dipoles.

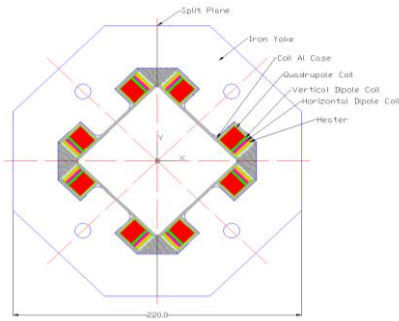

Fig. 2. The magnet package cross-section.

The magnet has a large bore defined by SCRF cavity aperture and rather short length which includes the pole length, coil ends and field clamps (see Fig.3).

TABLE I

LCLS-II MAGNET PACKAGE PARAMETERS

Parameter	Units	Value
Integrated peak gradient at 10 GeV	T	2.0
Integrated peak gradient at 0.4 GeV	T	0.05
Clear bore aperture	mm	≥ 78
Ferromagnetic pole tip bore diameter	mm	90
Effective length	mm	230.7
Peak quadrupole gradient	T/m	8.67
Quadrupole field non-linearity at 10 mm diameter	%	≤ 0.5
Quadrupole magnet inductance	H	0.66
Number of superconducting coil packages		4
Number of superconducting sections in the coil package		3
Number of turns in the quadrupole section		426
Number of turns in vertical/horizontal dipole sections		39
Peak superconductor current	A	≤ 20
NbTi superconductor dia.	mm	0.5
Superconductor filament size	μm	3.7
Dipole corrector integrated strength	T-m	0.005
Max magnetic center offset in Cryomodule	mm	≤ 0.5
Magnet physical length	mm	340
Magnet width/height	mm	322/220
Quantity required		37

Further magnet length reduction will compromise the magnet field quality. Because the beam size in SCRF Linacs is very small and the magnet is positioned with an accuracy of 0.5 mm, the needed good field area is also small. This substantially reduces demands on the magnet fabrication, and assembly tolerances.

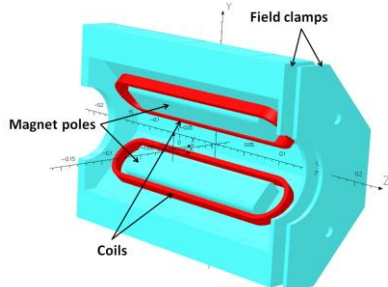

Fig. 3. One half of magnet package view.

The FNAL-KEK collaboration built two splittable conduction cooled magnets (see Fig.4). One was installed in the KEK ILC Cryomodule and another is used for the design verification and high precision magnetic measurements. These magnets have parameters very close to those of LCLS-II, shown in Table 1.



Fig. 4. The quadrupole magnet package cold mass.

III. MAGNET PACKAGE MAGNETIC MEASUREMENTS

The magnet package magnetic measurements were performed by rotational coils at FNAL Stand 3. This stand has a LHe vessel and the warm finger placed inside the magnet aperture. The rotational coil system utilizes a novel PC Board design [13], and provides a measurement accuracy better than 1 unit (10^{-4}). Initially, integrated field strength was measured at different currents (see Fig. 5).

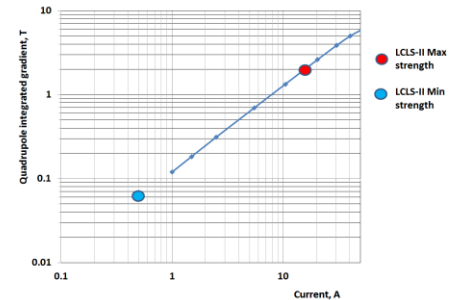

Fig. 5. Quadrupole magnet integrated gradient.

The magnet field grows linearly with the current and without iron yoke saturation effects. The 2 T peak integrated gradient was reached at 16 A current. The dipole corrector measurement results are shown in Fig. 6.

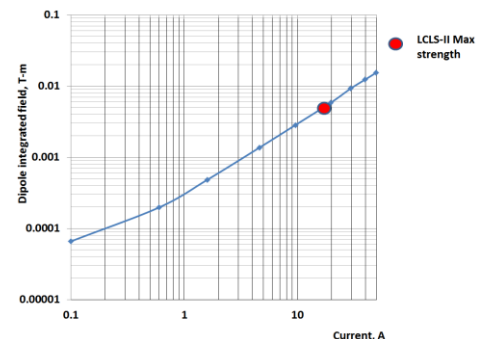

Fig. 6. Dipole corrector integrated field.

Field harmonic normal coefficients b_n measured by the rotational coil system are presented in Fig. 7 for the quadrupole, and in Fig. 8 for dipoles, versus harmonic order (where dipole $n=1$) at a wide range of currents.

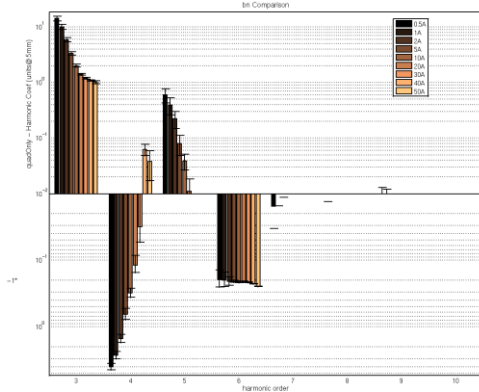

Fig. 7. Quadrupole normal integrated field harmonics.

One can see that the low order harmonics have a substantial increase at low currents. It might be caused by several effects: superconductor magnetization, iron yoke hysteresis, or external fringe fields.

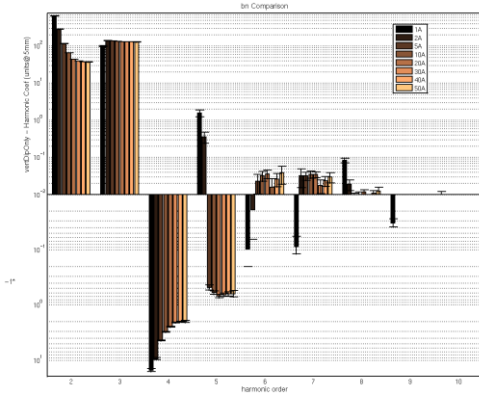

Fig. 8. Dipole integrated normal field harmonics.

Fringe field levels near the top of the cryostat were investigated. In some areas the field reached 4 Gauss, a level capable of substantially disturbing the field quality at low currents. To eliminate this effect, a series of measurements were obtained at positive and negative currents and subtracted, with the following results (see Fig. 9).

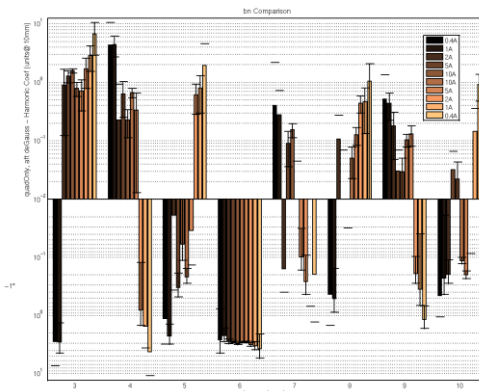

Fig. 9. Quadrupole integrated normal geometric field harmonics.

The geometric harmonics for the quadrupole are less than 10 units at 10 mm radius and meet specifications. The magnet was removed from the cryostat and magnetic measurements were repeated at room temperature for currents in the range of ± 0.4 A. The measured harmonics coefficients at 10 mm radius were: $b_3=4$ units, $a_3=0.7$ units, $b_6=3$ units. This confirms that the large harmonics of cold measurements were caused by external fringe fields. The influence of superconductor magnetization effects were shown to be negligible during field measurements made at 180 K as the magnet warmed up.

Another parameter of interest is the magnetic field reproducibility. The quadrupole winding was cycled in the range of 0–10 A. In Fig. 10 the magnet strength normalized to that at 10 A is shown for two successive ramp cycles.

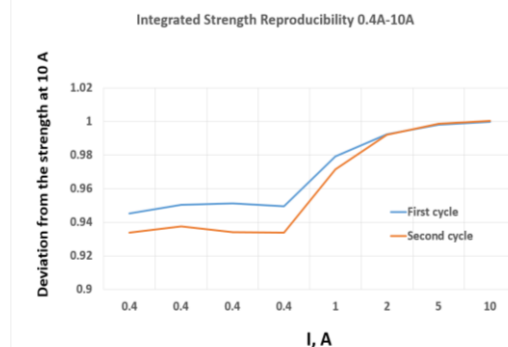

Fig. 10. Quadrupole strength reproducibility for multiple ramps.

Above 2 A the reproducibility is ~ 0.1 % and looks very good. For 0.4 A the difference in mean values is about 1.5 %. But there might be a significant systematic error because of manually set current values. The goal for the reproducibility is 1 % and could be reached at low currents by using standardizing cycles.

IV. CONDUCTION COOLING TEST

The magnet will be installed inside the cryomodule and will be conductively cooled. The conduction cooling verification test was performed in the FNAL Spoke Test Cryostat (STC). The magnet cooling configuration was reproduced as closely as possible to the cryomodule conditions. The magnet set up and current lead configuration is shown in Fig. 11.



Fig. 11. Magnet package combined with current leads and thermal sinks.

The magnet and current leads were cooled by conduction through pure A5N aluminum channels rigidly connected to (and electrically insulated from) copper block thermal intercepts on 2 K, 5 K and 80 K pipes in the cryostat. The

magnet and leads were heavily instrumented using Platinum and Cernox thermal sensors. Two independent DAQ systems continuously monitored temperature from 35 sensors mounted on two current leads, magnet, and thermal interceptors. The sensor positions are shown in Fig. 12.

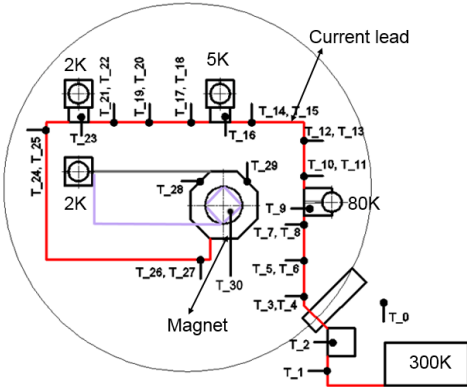

Fig. 12. Thermal sensors schematic. T31-35 were embedded with the coils.

The magnet, Lead 1 and thermal intercept temperatures were monitored using Cryocon meters through the ACNET system, and Lead 2 sensors using a Lakeshore LS224 meter and a PC running LabView. The cool down history is shown in Fig. 13.

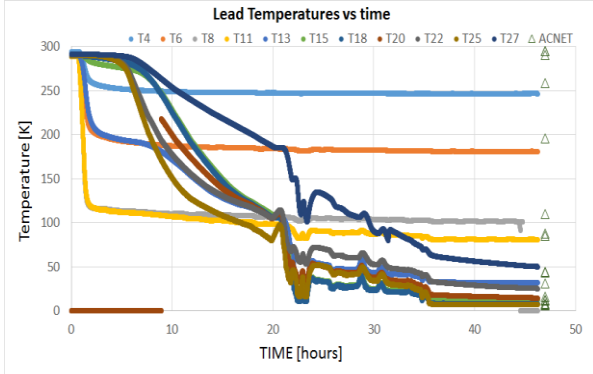

Fig. 13. Leads cooling down.

The magnet was cooled down to the superconducting state in 48 hours during 4 K operation. Several temperature sensors showed elevated temperatures (see Fig. 14). These sensors mounted in areas with difficult access, and thermal contacts or wire thermal intercepts might be compromised.

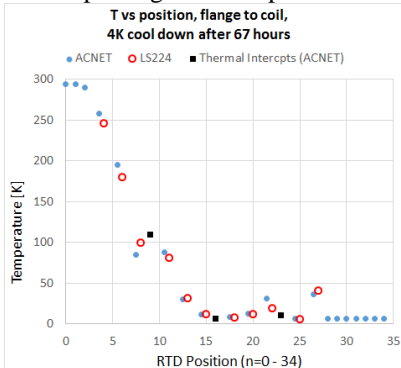

Fig. 14. Temperature profile along leads from 300 K to 4 K after 67 hours.

The system was then operated at 2 K by pumping to reduce the He temperature. Fig. 15 shows the temperature profiles at 4 K, and 2 K operation before magnet was powered.

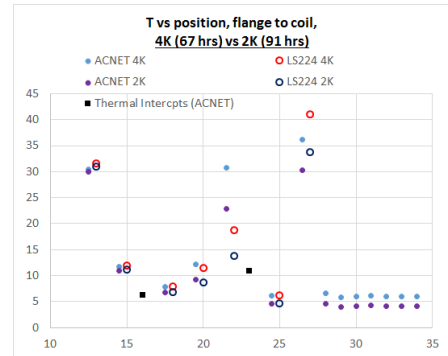

Fig. 15. The temperature distribution along the cold part of leads.

All sensors mounted on the magnet coils and yoke showed around 4 K temperature (sensors T₂₈ to T₃₅). It is obvious that sensors T₂₆ and T₂₇ could not have >30 K temperature when adjacent short lengths of copper lead were near 4 K.

This conclusion was confirmed by measurements with current that followed. The magnet was gradually excited with steps 2 A up to 20 A, allowing 15 min waiting time at each current to stabilize the temperature distribution. All three magnets were powered simultaneously at 20 A by independent power supplies with no heating observed for over 17 hours. Later the magnet currents were increased to 50 A with no coil quenches or current lead runaways, showing good margin.

All four coil packages have wire heaters connected in series and powered from an external power supplies. The heater study showed that using a current pulse it is possible to induce the superconducting coil transition to the resistive condition. Thus it can be used to clear superconductor magnetization to reduce as much as possible magnet fringe field when cooling down SCRF cavities, to avoid trapping this field in Nb superconducting material.

V. CONCLUSION

A short variant of the ILC splittable conduction cooled magnet package was thoroughly tested and showed good performance. It could be used in medium energy range linear accelerators which are now under design. The magnet package combines the quadrupole with dipole correctors. During cold tests the following features were observed and verified:

- The field quality is acceptable in the good field region.
- Measurements with opposite polarity confirmed that field geometric harmonics are low.
- Measurements at room temperature confirmed that the low field distortions were caused by fringe fields.
- The magnet was conductively cooled after 48 hours to the superconducting state.
- The magnet was successfully excited to 20 A (peak operating current for LCLS-II).
- The current leads and magnet have a large temperature margin and are able to work at the 50 A design current.

The successfully completed tests validated the conduction cooling design for use in the LCLS-II SCRF cryomodule. Two prototype magnets to be installed in the first cryomodules have been fabricated, and testing has started.

REFERENCES

- [1] "International Linear Collider Technical Design Report," June 2013, <http://www.linearcollider.org/ILC/Publications/Technical-Design-Report>
- [2] "TESLA Design Report," Hamburg, DESY 2001-11, 2001.
- [3] "Fermilab Proton Improvement Plan," PIP-II, 2013: http://www-ad.fnal.gov/proton/PIP/PIP_index.html
- [4] "Linac Coherent Light Source," LCLS-II, 2015: https://portal.slac.stanford.edu/sites/lcls_public/Pages/Default.aspx
- [5] A. Koski, R. Bandelmann, S. Wolff, "Superconducting magnet package for the TESLA test facility," *IEEE Transactions on Magnetics*, vol. 32, No. 4, July 1996, pp. 2155-2158.
- [6] F. Toral *et al.*, "Design and fabrication study on the TESLA500 superconducting magnets," *IEEE Trans. Applied Superconductivity* **12**, 282 (2002).
- [7] V.S. Kashikhin, *et al.*, "Test results of a superconducting quadrupole model designed for linear accelerator applications," *IEEE Transactions on Applied Superconductivity*, vol. 19, Issue 3, Part 2, June 2009, pp. 1176-1182.
- [8] V.S. Kashikhin, N. Andreev, Y. Orlov, D. F. Orris, and M. A. Tartaglia, "Superconducting Magnets for SCRF Cryomodules at Front End of Linear Accelerators," Proceedings of IPAC'10, Kyoto, Japan, 2010, pp. 379-381.
- [9] V. S. Kashikhin, N. Andreev, J. Kerby, Y. Orlov, N. Solyak, M. Tartaglia, and G. Velev, "Superconducting splittable quadrupole magnet for linear accelerators," *IEEE Trans. Appl. Supercond.*, vol. 22, no. 3, p. 4002904, June 2012.
- [10] N. Andreev, V. S. Kashikhin, J. Kerby, N. Kimura, M. Takahashi, M. A. Tartaglia, T. Tosaka, and A. Yamamoto, "Conduction cooling test of a splittable quadrupole for ILC cryomodules," *IEEE Trans. Appl. Supercond.*, vol. 23, no. 3, p. 3500305, June, 2013.
- [11] N. Kimura, N. Andreev, V. S. Kashikhin, J. Kerby, M. A. Tartaglia, and A. Yamamoto, "Cryogenic performance of a conduction cooling splittable quadrupole magnet for ILC cryomodules," *Adv. Cryogenics Engineering*, 59A, 2014, pp.407-415.
- [12] R. Carcagno, *et al.*, "Magnetic and Thermal Performance of a Conduction-Cooled Splittable Quadrupole," *IEEE Trans. Appl. Supercond.*, vol. 24, no. 3, p. 4001604, June, 2014.
- [13] J. DiMarco, *et al.*, "Application of PCB and FDM Technologies to Magnetic Measurement Probe System Development", *IEEE Trans. on Appl. Supercond.*, vol. 23, no. 3, 9000505, June 2013.