

Lifetime Test for Optical Transmitters in the ATLAS Liquid Argon Calorimeter Readout System¹

Cheng-An Yang, Tiankuan Liu, Chu Xiang and Jingbo Ye

Physics Department, Southern Methodist University, Dallas, Texas 75275, U.S.A.

Abstract

Accelerated lifetime test has been carried out for 147 days on the custom-made optical transmitters used in the ATLAS Liquid Argon Calorimeter front-end electronics readout system. The lifetime of these optical transmitters is estimated to be greater than 200 years and exceeds the design goal for the LHC. The random failure rate has been estimated at 9.6×10^{-7} per hour at 90% confidence level.

1. Introduction

Custom-made optical transmitters (OTx) for the ATLAS [1] Liquid Argon Calorimeter front-end electronics readout system were fabricated by the Academia Sinica Taiwan (AST) [2]. They have been designed by AST in collaboration with SMU to convert the electrical to optical signals for the optical readout of the front-end board (FEB). The OTx's performance has been thoroughly tested [3]. All production units had to fulfill parameters and signal criteria listed in Table 1.

Table 1. OTx specifications [3]

Parameters	Unit	Min.	Max.
Average optical power	dBm	-7.5	-3.5
Extinction ratio		6.0	
Rise time	ps		220
Fall time	ps		220
Deterministic jitter (peak-peak)	ps		125
Random jitter (RMS)	ps		10.24
Reference voltage	V	1.7	2.3

FEB components need to be highly reliable, because once put into operation, the access to the on-detector electronics is very limited. Therefore, a lifetime study has been carried out to evaluate the probability of failure of the OTx during the long term running of the experiment. The OTx is expected to operate in ATLAS for 10 years.

Lifetime determination under actual operational condition is not practical. A common practice for such estimate is an accelerated lifetime test. In such test, various stresses, within maximum operational ratings of all individual components of the system, are applied to the devices. These stresses physically and/or chronologically accelerate potential failures by forcing device degradation in order to determine a device's wear-out

¹ This work is supported by DOE grant DE-FG02-04ER41299

period. Accelerated lifetime tests can be performed at excess temperature, humidity, voltage, pressure, vibration, etc., in order to accelerate or stimulate the failure mechanisms. For the OTx, such failures may be due to mechanical fatigue, corrosion, chemical reactions, diffusion and charge migration within individual electronics chips, etc. The failure mechanisms under the applied stresses are kept consistent with those under normal operation; only the time scale is different. From such test, we can derive on statistical basis the device lifetimes and failure rates. Furthermore, individual failure mechanisms can be analyzed.

Comprehensive failure mechanisms are difficult to simulate, even when the best efforts are made to accelerate all stresses simultaneously. Therefore, to estimate accurately the lifetime of the OTx, test conditions are chosen such that failure mechanisms are relatively constant, few and simple. In practice, the most commonly used acceleration factors for optoelectronic devices are temperature, current, and optical power output. Extensive tests have produced lifetime predictions that are consistent with field reports [4]. The OTx is a subassembly package that allows limited control of current and optical power. Therefore, high temperature was chosen as the sole acceleration variable.

2. Test Description and Test Set up

2.1 Test Description

This test is designed as a Constant Stress Test. The test samples were randomly chosen from production batches. They were operated and monitored at a constant elevated temperature of 75°C in the test oven. The performance of key parameters and functions including a degradation of the average optical power were measured at fixed time intervals. The period of time that the test samples function properly while being exposed under the elevated temperature is used to estimate the lifetime of the OTx.

The laser driver chip operations must occur below 85°C [5]. This chip is enclosed in a mechanical metallic package placed on the Front-End Board. Since our measurements indicate a 10°C difference between the temperature outside of the package and the ambient temperature of the laser driver chip inside the enclosure, we set the oven temperature to 75°C.

There are two types of failure modes for optical device:

- Degradation failures, where an important parameter of the device drifts so far from its original value that the device no longer functions properly.
- Catastrophic failures—the end of component life; i.e., complete destruction of the device.

A degradation of 3 dB in average optical power is a commonly used criterion in the optoelectronics industry. Although in our particular application, the optical power margin is 10 dB, we still conservatively adapt this widely used 3 dB degradation as our failure criterion.

The sample size for this experiment was set to 8 modules because of the limitation of the testing boards as well as the available number of spare OTx modules.

2.2 The Test Setup

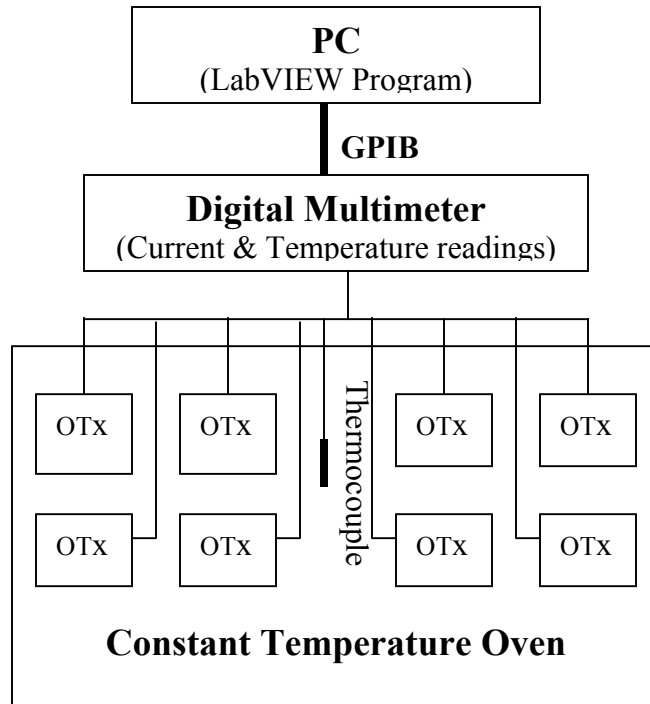

Figure 1. The Test Setup

All 8 OTx samples were placed inside the constant temperature oven with 5V bias and connected to a digital multimeter to monitor the current applied to each module.

A fan helped to equalize the air temperature inside the oven. A thermocouple placed in the oven was connected to a digital multimeter for temperature reading.

The multimeter was read out through GPIB and LabVIEW was used for a simple data acquisition program. The recorded online data were the oven temperature and the current through each OTx.

The lifetime test setup is shown in the following picture..

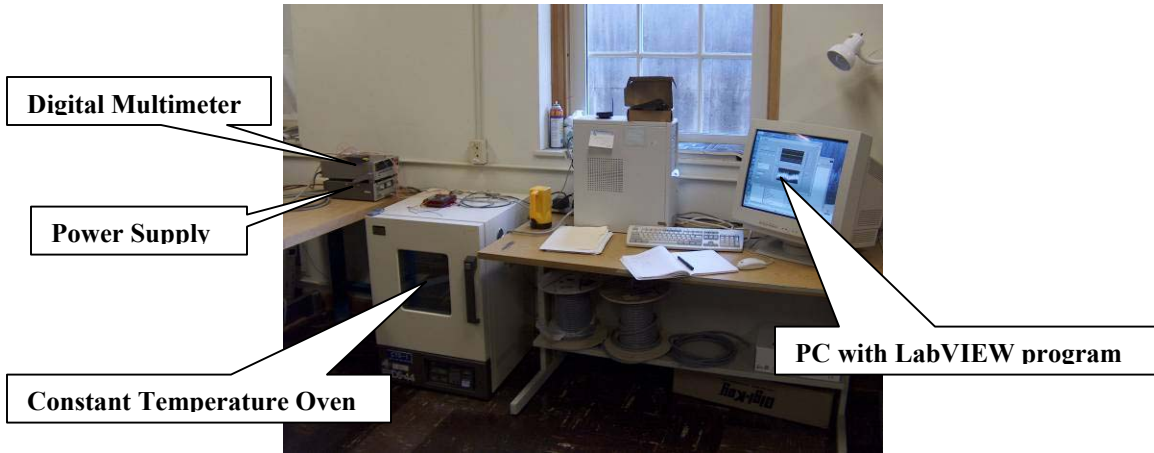

Picture 1. The lifetime test setup

3. Test Results and Analysis

Throughout the period of the test, measurements of average optical power, deterministic jitter, random jitter, rise time, fall time, extinct ratio, and the driver chip’s reference voltage were monitored with eye mask diagrams, I-V curve and bit error rate every 6-10 days.

At the end of the test all performance parameters of the testing samples were within the acceptable range of operations and no failure had been observed.

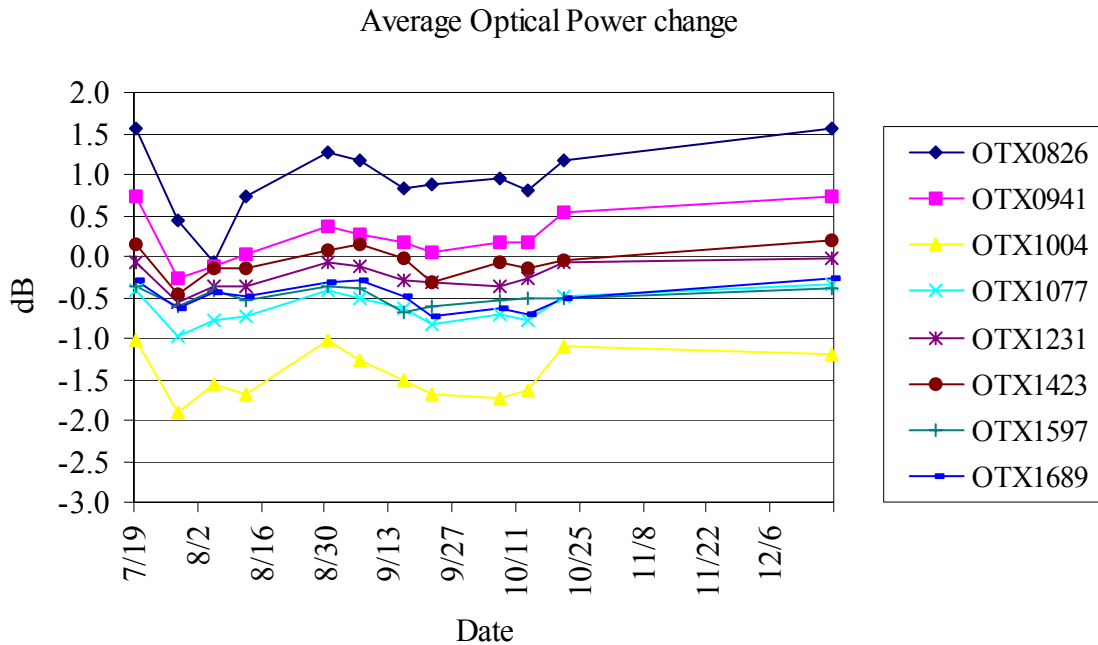

Fig.2 Average Optical Power change.

In Fig. 2 are shown changes of average optical power for each OTx unit. These changes are relative to the values measured at the start of the test. The largest degradation is less than 2 dB, and is well within the 3 dB budget.

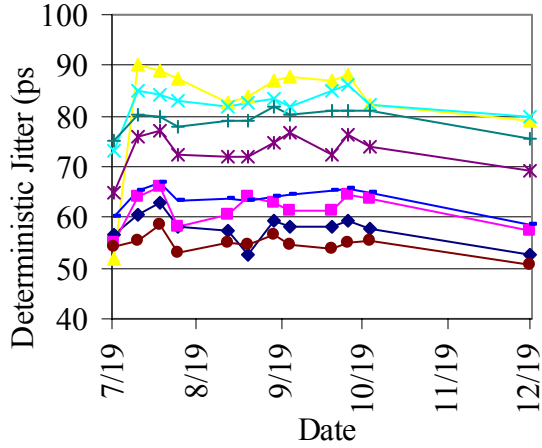

Fig. 3.1 Deterministic Jitter

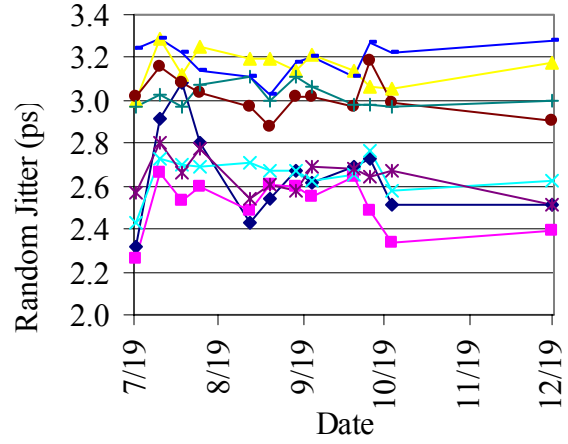

Fig. 3.2 Random Jitter

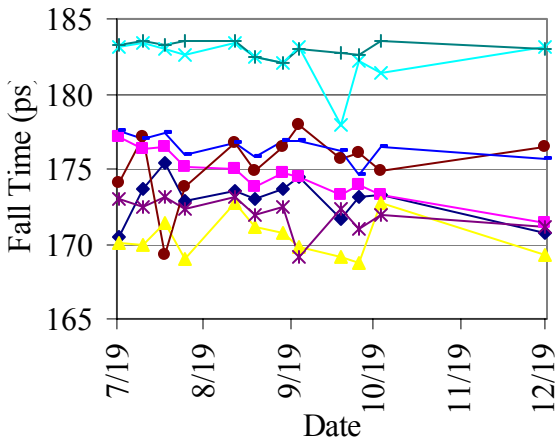

Fig. 3.3 Fall Time

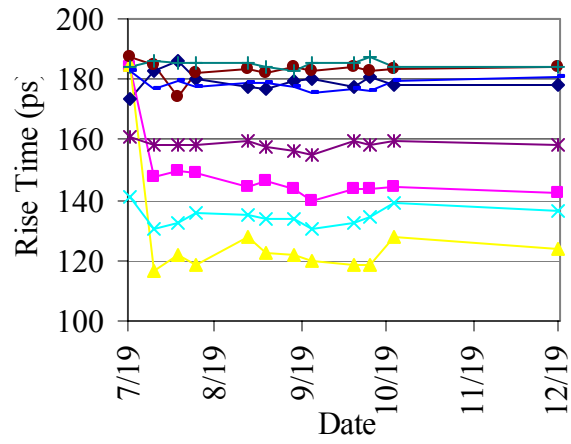

Fig. 3.4 Rise Time

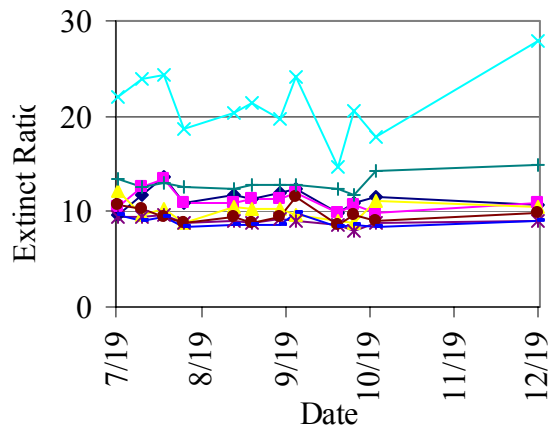

Fig. 3.5 Extinct Ratio

The parameters measured during the test are shown in Figs. 3.1 – 3.5. All the test samples are still well in the specification after 155 days running at the elevated temperature.

4. Analysis for OTx lifetime

4.1 Arrhenius Model

The Arrhenius life-stress model is a commonly used physics-based model derived for tests depending on temperature[4].

The physical and chemical reactions inherent in device degradation can be treated as examples of chemical kinetics. Chemical kinetics is a chemical reaction model that describes the temperature dependence of failures; it is used within the Arrhenius model in accelerated lifetime tests of semiconductor devices to measure the response to temperature stress.

Assuming the reaction speed is K , the Arrhenius equation can be expressed as:

$$K = A \exp(-E_a/kT) \quad (1)$$

Where A : Proportional Constant,

E_a : Activation Energy²,

k : Boltzmann's constant (8.617385×10^{-5} eV/K),

T : Temperature in Kelvin.

If the product's life is assumed to end when a certain degradation ' a ' is reached, then lifetime can be expressed as $L = a/K$. When $a/A = A'$ is substituted, we have:

$$L = A' \exp(E_a/kT) \quad (2)$$

This equation expresses the relationship between temperature and lifetime. If the failure mechanism is kept the same during accelerated test and normal operation, the quantities $\ln(L)$ and $1/T$ have linear dependence. Assuming the lifetimes at temperatures T_1 and T_2 to be L_1 and L_2 , respectively, the acceleration coefficient can be obtained as:

$$L_2/L_1 = \exp[Ea/k \cdot (1/T_2 - 1/T_1)] \quad (3)$$

² The activation energy is the energy that a molecule must have to participate in the reaction. In other words, the activation energy is a measure of the effect that temperature has on the reaction. The activation energy on the manufacturers' data sheets for VCSEL and laser driver chip, the key components in the OTx, are 1.0 eV[6] and 0.7 eV[4] respectively. In this test, we use 0.7 as activation energy to conservatively estimate the lifetime of the OTx.

4.2 Median Life of OTx

The median life is the time for which 50% of the population has failed obtained from a fit of the data to a lognormal distribution function³. The standard deviation (σ) of the distribution indicates the width of the distribution (i.e., the relative period over which the failures will occur). [7]

We estimate the median life of the OTx by linearly extrapolating all 8 sets of data:

$$P(t) - P(0) = Bt + C \quad (4)$$

$P(t)$ is Optical Power Output at time t .

From the plot of all 8 predicted wear-out lifetimes on the lognormal probability sheet, our estimation for the median life (ML) of OTx is 30000 hrs (75°C) with $\sigma = 1$.

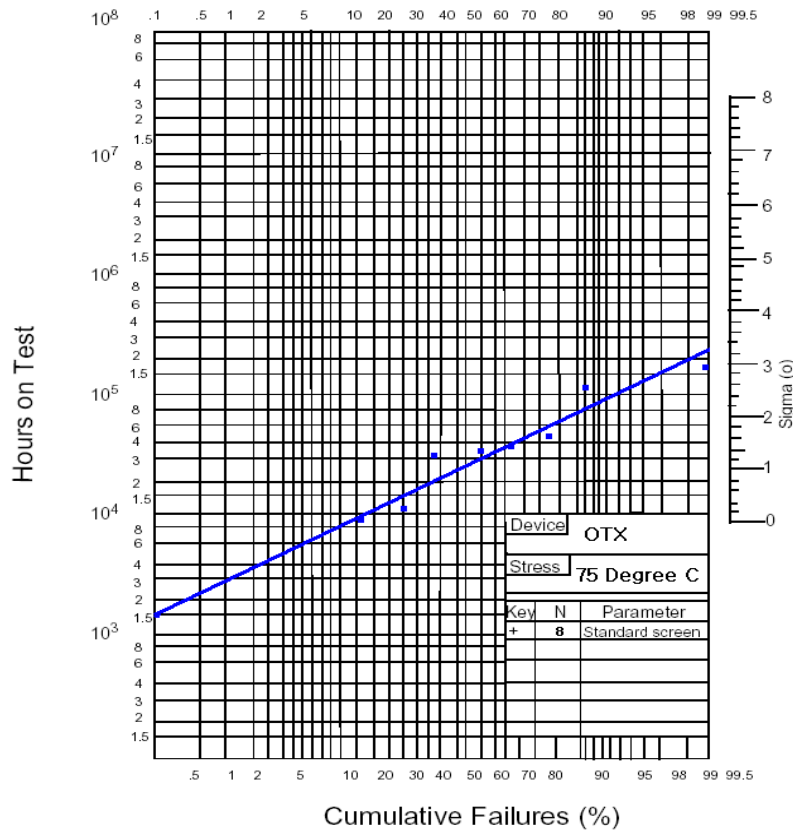

Figure 4. Lognormal Probability Plot Sheet

³ For the lognormal distribution, median life is a more convenient measure of central tendency than the mean time to failure (MTTF), unlike the latter, median life is independent of σ . Also, the median life is always a more conservative estimated lifetime than MTTF in lognormal distribution

We chose lognormal distribution as our prediction model because among the three models that are usually used for the statistical treatment of lifetime test data on optoelectronic devices: Logarithmic-normal (lognormal) distribution, Weibull distribution, and exponential distribution, the lognormal model can be theoretically derived under assumptions matching many failure degradation processes common to optoelectronic failure mechanisms and is usually used as the probability density function in the wear out failure period [8]. Equation (5) is the probability density function of failure of the lognormal model.

$$f(t) = [1/(2\pi)^{1/2} \sigma t] \exp\{(-1/2\sigma^2)[\ln(t/t_m)]^2\} \quad (5)$$

Where t : Operating Time,
 t_m : Median Life,
 σ : The Standard Deviation in the lognormal distribution.

σ is calculated using following equation [7]:

$$\sigma = [\ln(t_{84}) - \ln(t_{16})]/2 = [\ln(80000) - \ln(11000)]/2 \approx 1 \quad (6)$$

Here t_{84} , t_{16} are the hours for 84% and 16% failures, respectively (taken from the plot).

Applying this information to the Arrhenius equation and using 75°C and 20°C respectively as the ambient temperatures of testing and actual operating temperatures, the ML of the OTx is more than 2.4×10^6 hours, that is about 274 years usage time.

4.3 Wear out Failure Rate

The wear out failure rate under a given median life and a standard deviation in lognormal distribution, at time t , is defined as:

$$\lambda(t) = \lim_{h \rightarrow 0} \frac{R(t) - R(t+h)}{hR(t)} = \frac{f(t)}{R(t)} \quad (7)$$

Where $R(t) = \int_t^{\infty} f(x)dx$ is the probability for a device to survive at time t , with $f(t)$ the probability density function defined in equation (5).

The Goldthwaite Curve[9] plotted this failure rate times the ML (in hours) at time t (normalized by ML), with different σ values, at 20°C. From the curve of $\sigma=1$, the maximum wear-out failure rate is 417 FITs⁴ (4.17×10^{-7} per hour) at the calculated ML.

⁴ A FIT, or Failure Unit, corresponds to failures per billion-hours.

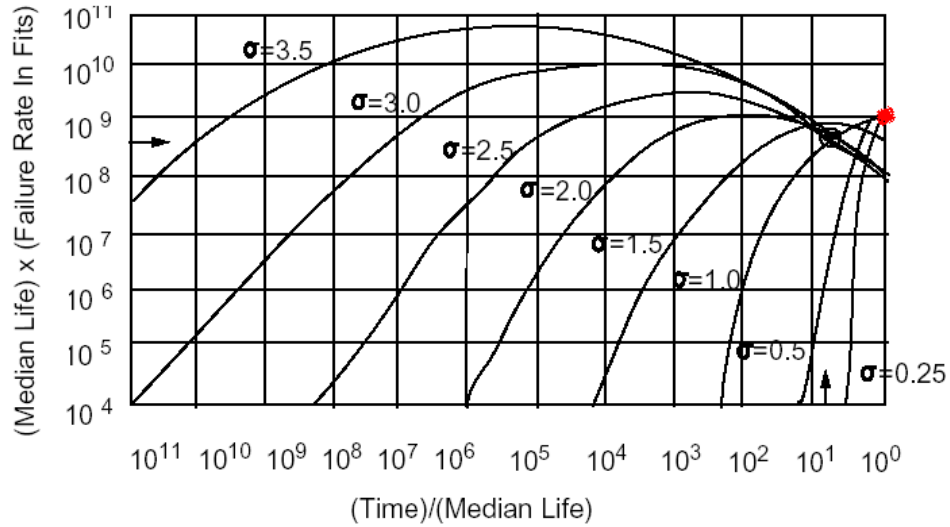

Figure 5. Goldthwaite Curve

4.4 Random Failure Rate

The random failure rate reflects the probability of failures not associated with infant mortality and wear-out mechanisms. Infant mortality failures are ruled out by the burn-in procedure in production. The wear-out failures mostly happen at the end of the device lifetime. The random failure rate is assumed to be constant over time, reflecting bottom part of the “bathtub curve” [8]. The exponential distribution is the only distribution to have a constant failure rate and it is used to model random failures

$$f_R(t) = \lambda_R \exp(-\lambda_R t) \quad (8)$$

λ_R : Random Failure Rate.

For applications that involve optoelectronic devices, λ_R can be approximated as the following: [7].

$$\lambda_R = (10^9 \cdot N \cdot \gamma) / t_{tot} \quad (\text{in unit of FIT}) \quad (9)$$

Where N = number of failed devices;

t_{tot} = total tested device hours (at operation temperature) derived from the Arrhenius model,

$\gamma = 0.92$ (60% Confidence Level when $N = 0$),

$\gamma = 2.30$ (90% Confidence Level when $N = 0$).

In this test, $t_{tot} = 8 \times 299480$ (from Arrhenius model) hours, and there is no device that failed during the test, so $N = 0$.

Since $N = 0$, we use the γ value when $N = 0$ and use $N = 1$ in equation (9) to get a conservative estimation: $\lambda_R = 383.5$ FITs (3.8×10^{-7} per hour, 60% C.L.) and $\lambda_R = 960$

FITs (9.6×10^{-7} per hour, 90% C.L.). The random failure rate of $\lambda_R = 960$ FITs corresponds to a system failure of $1600 \text{ (units)} \times 9.6 \times 10^{-7} (\lambda_R) \times 356 \times 24 \text{ hour} = 13$ units, for a 1600 unit system and for one year of operation. If we assume the failed units are replaced on yearly basis, we need 130 units as spares, or 8% spare is required. We need to point out though, since we didn't observe any failure during the test, this estimated number is an upper limit for the random failure rate.

5. Conclusion

After 155 days under testing condition, all the parameters of the 8 OTx devices under test are still within range of the specification. The estimated median lifetime for the OTx at 20°C is more than 274 years, exceeds the required 10 years operation lifetime by a large margin. The random failure rate is estimated to be 960 FITs (90% C.L.). The wear out rate will maximize at the calculated ML and reaches 417 FITs. The estimated spare units for random failure replacement are less than 130 units, for a system of 1600 unit in a 10 year operation span. This conservative estimate doesn't exceed the 8% device spare rate set in the OTx production.

Acknowledgements

The authors would like to thank the Taiwan production team for the OTx at the Academia Sinica: Ming-Lee Chu, Shih-Chang Lee, P.K. Teng *et.al* for the information and the insightful suggestions. The authors would also like to thank our colleagues and collaborators in ATLAS, especially John Parsons, Stefan Simion and Gary Evans for their support, suggestions and guidance in this project.

References

1. <http://atlas.web.cern.ch/Atlas/index.html>
2. <http://www.sinica.edu.tw/>
3. Tiankuan Liu, Yuping He, Cheng-An Yang, Benjamin E. Wakeland, and Jingbo Ye, "Quality control of optical transmitters for the ATLAS liquid argon calorimeter." SMU-HEP-04-10, ATL-LARG-PUB-2005-004.
4. Jim A. Tatum, Andrew Clark, James K. Guenter, Robert A. Hawthorne, and Ralph H. Johnson, "Commercialization of Honeywell's VCSEL Technology", *Proceeding of the SPIE* Vol. 3946, SPIE, 2000.
5. http://www.micrel.com/_PDF/qualrel/FIT-MTBF/ASSET1_2.pdf.
6. http://www.micrel.com/_PDF/HBW/sy88922v.pdf
7. GR-468-CORE, *Generic Reliability Assurance Requirements for Optoelectronic Devices Used in Telecommunications Equipment (a module of RQGR, FR-796)*, issue 1, Bellcore, December 1998.
8. Mitsuo Fukuda, *Reliability and Degradation of Semiconductor Lasers and LEDs*, Artech House, Norwood, MA, 1991.
9. L.R. Goldthwaite, "Failure Rate Study for the Lognormal Lifetime Model", *Proceedings of the 7th Symposium on Reliability and Quality Control*, 1961, pp. 208-213; the use of Goldthwaite plots is described in *Accelerated Testing Handbook* by D.S. Peck and O.D. Trapp, Technology Associates (Portola Valley, CA, 1981).