

International Conference "Synchrotron and Free electron laser Radiation: generation and application", SFR-2016, 4-8 July 2016, Novosibirsk, Russia

HYBRID MAGNET WIGGLER FOR SR RESEARCH PROGRAM AT VEPP-4M

G. Baranov^{a,b,*}, P. Vobly^a, E. Levichev^{a,b}, P. Piminov^a, K. Zolotarev^a, Y. Kolokolnikov^a, S. Shiyankov^a, N. Havin^a, Y. Pupkov^a, V. Svishev^a, G. Denis^a, A. Utkin^a, V. Zuev^a

^a*Budker Institute of Nuclear Physics, Novosibirsk 630090, Russia*

^b*Novosibirsk State Technical University, Novosibirsk 630073, Russia*

Abstract

A compact hybrid magnet wiggler is under development for the VEPP-4 SR research program. The wiggler allows increasing the photon flux two orders of magnitude at a beam energy of 4.5 GeV in the spectrum range of 60-100 keV. The magnet consists of conventional coils, which generate a magnetic field, and permanent magnet insertions, which concentrate the flux. This solution increases the field in the beam orbit up to 2.05 T. Here we present the design, magnetic calculations and analysis of the beam dynamics under the hybrid wiggler influence.

© 2016 The Authors. Published by Elsevier B.V. This is an open access article under the CC BY-NC-ND license (<http://creativecommons.org/licenses/by-nc-nd/4.0/>).

Peer-review under responsibility of the organizing committee of SFR-2016.

Keywords: Wiggler, hybrid magnet, synchrotron radiation, light source, magnetic calculation, photon flux, magnetic field, permanent magnets;

1. Introduction

Now the major part of the research on interaction of radiation with matter in the ultraviolet and X-ray spectral region is carried out using high-power synchrotron radiation from cyclic electron accelerators and storage rings. Synchrotron radiation is a powerful tool for up-to-date research, from materials science to biology and medicine. The brightness and energy of photons are important parameters of radiation. Magnets with a spatially periodic transverse field are intended for SR generation. Such magnets are referred to "wignlers" or "undulators" [1].

* Corresponding author. Tel.: +7-383-329-4951; fax: +7-383-330-7163.

* *E-mail address:* g.n.baranov@inp.nsk.su

Third-generation sources of synchrotron radiation are storage rings designed specifically to generate radiation using wigglers and undulators. Choosing parameters of such devices, it is possible to produce radiation with optimal characteristics: spectrum, flow, brightness, divergence, and so on.

A hybrid wiggler for the accelerator complex VEPP-4M is being created at BINP (see its main parameters in Table 1). The accelerator complex VEPP-4M at BINP has been working at energies of up to 6 GeV since 1994. At present, the main high-energy physics experiment at VEPP-4M is the precise measurement of the mass of tau-lepton at its production threshold. Experiments for improvement of the accuracy of the measured masses of $\psi(2s)$ and $\psi(3770)$ mesons are also continued (the beam energy range is 1840-1900 MeV). In the low energy range (1.5-3.0 GeV), the peak luminosity of the collider is $2 \cdot 10^{30} \text{cm}^{-2} \text{s}^{-1}$. There are also experiments with the use of synchrotron radiation. For this purpose, the radiation of the 7-pole wiggler has been applied (see parameters in Table 2) [2-4].

Table 1. Main parameters of VEPP-4M

		Old wiggler	New wiggler
Circumference	m	366.07	2.05
Energy	GeV	1.5-6	14
Emittance (1.85 GeV)	nm·rad	26.4	7
$\Delta E/E$		$3.22 \cdot 10^{-4}$	9
Pole gap	cm	4	3
Momentum compaction factor		0.0168	

2. Hybrid wiggler design

A compact hybrid wiggler is under development for the VEPP-4 SR research program. This device will replace the old wiggler and provide a large flux of photons, hard spectrum, and a wide radiation beam of about 150 mm. Table 2 compares the characteristics of the old wiggler and the new one [2]. The new wiggler will significantly expand the program of research using synchrotron radiation realized at BINP. The wiggler is planned for exploration of fast processes and interaction of materials at high speed, analysis of massive samples, and micro-beam cancer therapy, as well as dynamic study of material under influence of strong electromagnetic fields for development of materials for fusion reactors [2, 3].

Table 2. Old and new wigglers at VEPP-4M

		Old wiggler	New wiggler
B_{\max}	T	1.2	2.05
Period length	cm	20	14
Number of main poles		5	7
Total number of poles		7	9
Pole gap	cm	4	3

The pole gap of the new wiggler is 30 mm, which is about 10 mm smaller than that of the old wiggler, only the vertical dimension of the vacuum chamber changed. The wiggler contains 9 poles. The side poles have a half strength. The poles are made of non-laminated electrical steel. The presence of permanent magnet between the poles makes this device a hybrid. Fig. 1 shows the hybrid wiggler. It consists of seven main poles and two poles with half field (1/2; -1; 1; -1; 1; -1; 1; -1; 1/2).

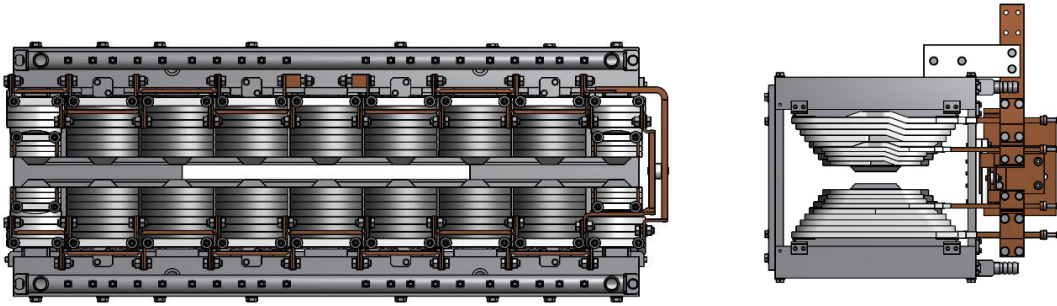

Fig. 1. Hybrid wiggler

The side poles have correction coils, which allow adjustment of the field integrals. An overall view of the poles is shown in Figure 2. Each coil contains 16 turns. The operation of the device requires a power supply with a current of up to 2 kA and voltage of about 60 V.

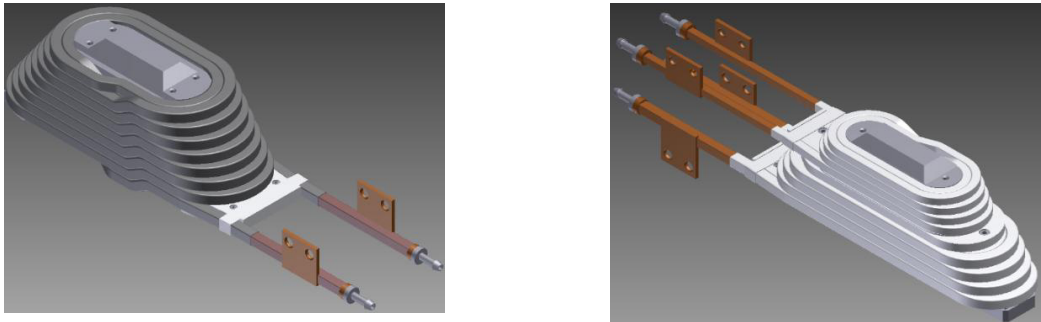

Fig. 2. Main pole with coil (left); side pole with coil (right).

In order to increase the field in the gap we installed NbFeB permanent magnets between the poles. The magnetization of the permanent magnets is directed along/against the beam movement (Fig.3).

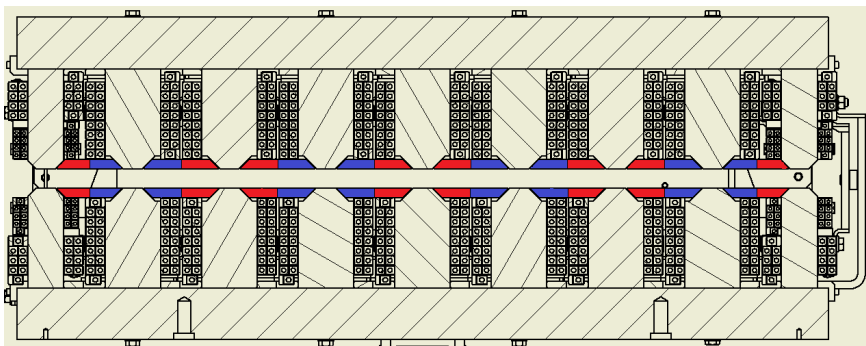

Fig. 3. Poles with permanent magnets (marked blue/red).

The magnetization of the permanent magnets is 1.2 T, which gives a 0.2 T increase in the field in the gap. The permanent magnets take part of the magnetic flux and prevent saturation of the lower part of the pole (Fig. 4).

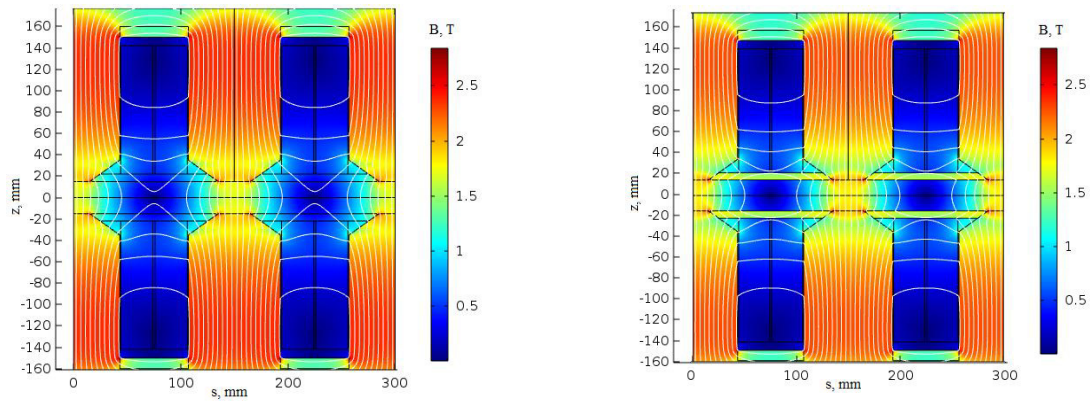

Fig. 4. Distribution of magnetic field in wiggler without permanent magnets (left); distribution of magnetic field in wiggler with permanent magnets (right)

3. Parameters of radiation

The radiation was calculated using the SPECTRA program. The most popular energy ranges are 30-40 keV for the detonation station and 100 -120 keV for the station for phase contrast microscopy, microtomography, and X-ray fluorescence analysis [3, 4]. In the latter case, an approximately 30-fold improvement of the current situation is expected. We calculated the photon flux density at an electron energy of 4 GeV and a current of 20 mA. Fig. 5 shows the results of calculations for the old and new wigglers.

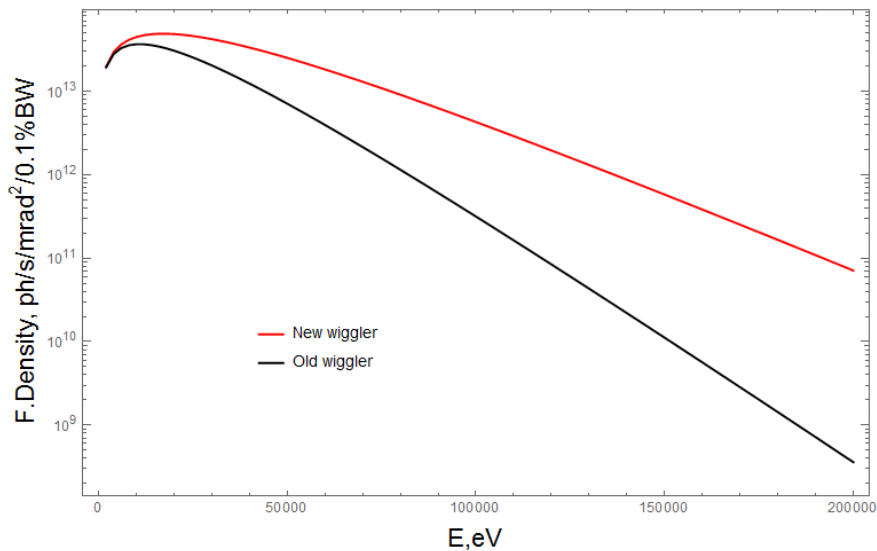

Fig. 5. Flux density for old and new wigglers.

4. Beam influence

As a model of the wiggler we chose alternating rectangular magnets with straight intervals between them, as shown in Fig. 6.

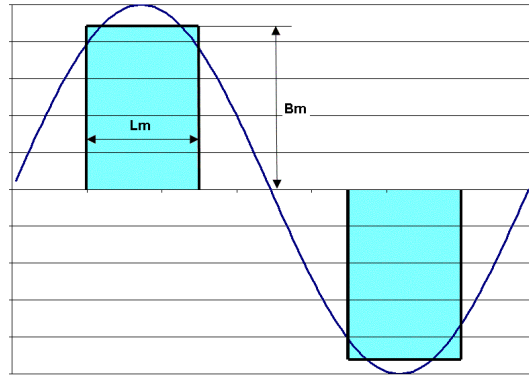

Fig. 6. Model of wiggler for calculation

Table 3 shows the main parameters of the structure with and without the wiggler [5-6].

Table 3. Main parameters of wiggler

	Wiggler off	Wiggler on	Δ
v_x	8.6847	8.69	0.005
v_y	7.73	7.73	0
I_1 (m)	6.142	6.125	
I_2 (m ⁻¹)	0.197	0.21	
I_3 (m ⁻²)	0.0072	0.0091	
I_5 (m ⁻²)	0.0015	0.0021	

5. Conclusion

The new wiggler will significantly expand the scientific program at BINP. In addition, this device has record characteristics in the segment of normal conduction, and its design is simple.

Acknowledgements

This work was supported by grant 14-50-00080 of the Russian Science Foundation

References

1. Motz H J. Appl. Phys. 22 527 (1951)
2. B.P.Tolochko. The prototype of Plasma station with synchrotron radiation beam from 7-pole wiggler of VEPP-4 storage ring (in Russian). Journal of Structural Chemistry, 8, 2016
3. Ancharov A, Zolotarev K. Using hard synchrotron radiation for the diffraction investigation.
4. E.B.Levichev. Status and perspectives of VEPP-4 complex (in Russian). Particles and Nuclei, Letters, XIII, 7, 2016.
5. H. Wiedemann, Particle Accelerator Physics, Springer (1993)
6. M. Sands, Physics with Intersecting Storage Rings, Academic (1971)