

Dark-Matter QCD-Axion Searches

Leslie J Rosenberg

University of Washington, Department of Physics, Seattle, Washington USA

ljrosenberg@phys.washington.edu

Abstract. The axion is a hypothetical elementary particle appearing in a simple and elegant extension to the Standard Model of particle physics that cancels otherwise huge CP-violating effects in QCD; this extension has a broken U(1) axial symmetry, where the resulting Goldstone Boson is the axion. A light axion of mass $10^{-(6-3)}$ eV (the so-called “invisible axion”) would couple extraordinarily weakly to normal matter and radiation and would therefore be extremely difficult to detect in the laboratory. However, such an axion would be a compelling dark-matter candidate and is therefore a target of a number of searches. Compared to other dark-matter candidates, the plausible range of axion dark-matter couplings and masses is narrowly constrained. This restricted search space allows for “definitive” searches, where non-observation would seriously impugn the dark-matter QCD-axion hypothesis. Axion searches employ a wide range of technologies and techniques, from astrophysical observations to laboratory electromagnetic signal detection. For some experiments, sensitivities are have reached likely dark-matter axion couplings and masses. This is a brief and selective overview of axion searches. With only very limited space, I briefly describe just two of the many experiments that are searching for dark-matter axions.

1. What makes up the dark matter?

As is well known, the vast majority of all matter in the Universe is comprised of something other than dust, planets, gas...the ordinary matter we see around us. From observations of velocities in rich galactic clusters, plus those clusters’ gravitational lensing of background “candles”, as well as precision measurements of cosmological parameters, we now have a robust estimate of the dark matter fraction of the Universe of around one-quarter of its total energy density. Almost all the remaining mass-energy density of the Universe is the mysterious “dark energy”, a uniformly-distributed energy driving outward acceleration of the universe. Here on Earth, the nearby dark matter amounts to around $\frac{1}{2}$ of proton mass per cc; this is adduced from observations of our Milky Way dynamics, plus micro-lensing rates of MACHOs observed towards the galactic center.

From constraints imposed by structure formation in the Universe, plus the remnant light-isotope abundance left from the Big Bang, our good guess is that the dark matter is some particle relic left over from the Big Bang. A number of particle candidates have been proposed, two of which have properties that fit all the observations. These two are WIMPS and axions. WIMPs are neutral particles with mass in the 100 GeV range and having about weak-interaction couplings. Such particles have the properties of dark matter and would have frozen out in the early universe with about the right density to be dark matter. Much of the interest in WIMPs is driven by interest in the theory of Super

Symmetry, which provides a WIMP candidate, the neutralino. Equally well-motivated, but less well-known, is the axion. (See reference [1] for an overview of the axion.)

2. What is the axion?

Quantum Chromo Dynamics (QCD) was firmly established in the early 1970's as the underlying quantum theory of the nuclear interactions. It was remarkably successful, predicting, e.g., the structure of hadronic jets and the "running" of the strong coupling constant. However, by the mid-1970's it was realized this same theory predicts huge CP-violating interactions from "instanton" (multiple degenerate vacua) effects. One such effect would be a large permanent electric dipole moment in a spinning non-degenerate object bound by the strong interaction, e.g., the neutron.

In one of the most pleasing series of measurements in modern physics, the neutron is observed to have a vanishingly small upper bound to its permanent electric dipole moment. This strongly suggests QCD, despite its successes, is not the whole story of the strong interactions. In 1977, Roberto Peccei and Helen Quinn proposed a hidden U(1) axial symmetry of the quarks that had the effect of cancelling the unphysical strong-CP effects. Steven Weinberg and Frank Wilczek shortly thereafter realized such a symmetry, unseen in nature and therefore manifestly broken, implies the existence of a new pseudoscalar Goldstone-boson, the axion [2].

The properties of a light (in the μeV mass range) axion make for an ideal dark-matter candidate. In the Big Bang, axions appear as a zero-temperature Bose condensate, remaining at near-zero temperature and never in thermal equilibrium with the rest of the Universe. The axion, having the same quantum numbers as the π^0 , can similarly decay into two photons, but its lifetime is vastly longer than the age of the Universe. Most importantly, sufficiently light axions would have density to be the dark matter. Much lighter ($\ll \mu\text{eV}$) and axions would have severely overclosed the Universe. Much heavier ($> \text{meV}$) and axions produced in supernova sn1987a would have efficiently transported energy out of the explosion, thereby observably shortening the neutrino arrival pulse length recorded on Earth. These bounds result in an allowed axion mass window of $10^{-(6-3)}$ eV. Such light axions, while possibly supplying the dominant form of matter in the Universe, have interactions so feeble as to render them nearly "invisible" to normal matter and radiation.

3. Overview: Present limits on dark-matter axions

The axion has a wide variety of couplings and decay modes; think of the π^0 and its complexity; add to that a new U(1) axial symmetry with its new charges, and the model-space of couplings is large. However, there's a great simplification for the axion decay $a \rightarrow \gamma\gamma$. This two-photon decay rate, characterized by an effective coupling constant $g_{a\gamma\gamma}$, contains the ratio of color and electromagnetic anomalies of the new U(1) symmetry. Hence, this rate doesn't depend explicitly on the value of the axion's U(1) couplings since they cancel in the ratio. Even those measurements that depend on other decays and interactions other than with two photons are often cast into terms of constant $g_{a\gamma\gamma}$ to allow differing measurements and limits to be compared.

Figure 1 shows selected limits on axion couplings and masses from a variety of techniques. The horizontal axis is the putative axion mass. The vertical axis is the effective coupling of the axion into two photons. "KSVZ" and "DSVZ" refer to two benchmark classes of axion models commonly targeted by searches; in a sense they represent the extremes of allowing axions to couple with optional "full" or zero QCD strength to leptons. Dark-matter axions have properties that put them somewhere between the "KSVZ" and "DSVZ" couplings and in the mass range 1-10 μeV (or possibly 1-100 μeV). Not shown in figure 1 is the very restrictive upper bound to the coupling inferred by sn1987a, which is

a horizontal line around a coupling strength of $10^{-13}/\text{GeV}$. Notice the wide variety of measurements. At the upper left, terrestrial measurements look for effects of interactions of photons with virtual axions in the propagation of light. Just below in the figure, axions can affect the properties of the Sun in several ways, including its seismic signature and energy output. As well, those same solar axions could scatter off a germanium crystal at the appropriate Bragg angle and convert into x-rays. To the right, axions in halos of astrophysical objects could spontaneously decay into pairs of optical photons, subsequently detected in telescopes. None of these methods are sensitive to dark-matter QCD axions of the expected couplings and masses. In the dark-matter band, next in sensitivity are astrophysical bounds. Here, axion emission from astrophysical objects would observably affect the evolution of those objects. Such objects include stars along the red giant horizontal branch and white dwarfs. More recently, the CERN Axion Solar Telescope, aiming to detect axions emitted from the Sun, achieved sensitivities superior to the usual astrophysical bounds. One important bound is that from axion emission in supernovae. As I mentioned, such emission would have shortened the neutrino burst duration detected on Earth seen from sn1987a. This gives by far the astrophysical coupling-constant constraint of around $10^{-13}/\text{GeV}$. But even there, the sn1987a bounds lack adequate sensitivity to dark matter axions. However, a technology of converting nearby axions remaining from the big bang into microwave photons (“microwave cavity” on the figure) is indeed sensitive to plausible dark-matter axion masses and couplings.

Figure 1 shows only a sampling of the limits and technologies. Much more information on axions and limits is contained in the summary[1] and references therein. But since the topic here is dark-matter QCD axions, a simplification results since most technologies are by far too insensitive. While those searches may be sensitive to unusual axion variants, they don’t speak to the well-motivated QCD dark-matter axion hypothesis. I therefore restrict further discussion to the astrophysical bounds and the RF cavity technique and I’ll pick one experiment from each as an example. While from figure 1 it appears the astrophysical bounds don’t achieve adequate sensitivity, this may not be so. In particular, axion emission in those objects may not depend directly on the axion-to-two-photon coupling, so the emission rate is highly uncertain. For instance, axions emitted via nuclear bremsstrahlung, unlike the two-photon coupling, does depend on the unknown new U(1) axial charge of the quarks. It may well be that those astrophysical bounds are more sensitive than heretofore assumed. One may then wonder whether the astrophysical bounds (“HB Stars” on the figure) are already well excluded by the considerably more restrictive sn1987a bound. This may be, but plasma effects in supernovae explosions are important and difficult to calculate. Hence, the supernovae axion emission may be suppressed, which considerably softens the supernovae bound, which in turn increases the discovery potential of the other astrophysical bounds.

4. Example search: The CERN Axion Solar Telescope (CAST)

Axions would be emitted by the Sun with their kinetic energies in a broad distribution centered at 3 keV. The idea of detecting these axions via their conversion into x-rays goes back several decades, to an paper by Pierre Sikivie. The first serious implementation of this was an effort at Brookhaven National Laboratory. A larger and more sensitive instrument was built, and recently recommissioned, at the University of Tokyo. Figure 2 shows a sensitive instrument based on this method, the CERN Axion Solar Telescope (CAST)[2]. It features state-of-the art x-ray optics and detectors at the ends of a long, high-field LHC prototype dipole magnet. The entire assembly rides on a telescope mount that keeps the magnet axis aligned with the Sun for several hours at dawn and dusk. Axions would be signaled by an excess of counts in the x-ray detectors. As the axion-to-photon conversion rate is quadratic in field-strength and conversion length (until the onset of decoherence), and the x-ray detection efficiency is high, CAST represents a significant advance in the sensitivity of this technology.

The first phase of this experiment operated the magnet bore in a vacuum, results of which are shown in figure 2. No axion signal was observed. This configuration was sensitive to axions in the mass range up to a few 10's of meV, beyond which the axion mass was poorly matched to the photon dispersion relation with result the axion-to-photon conversion rate plummets. This result was notable for being at or more sensitive to the astrophysical bounds, and perhaps even sensitive to plausible dark-matter axion couplings at the more massive end of the search range.

At higher axion masses, in order to match the axion and photon dispersion relations, the magnet bore is backfilled with ^4He or ^3He gas at controlled pressure. At higher pressures, the peak of the conversion efficiency shifts to higher axion masses. This next experiment phase is in operation and the goal is to have sensitivity to axions with masses up to around an eV with couplings near that of the astrophysical bounds.

5. Example search: The Axion Dark-Matter eXperiment (ADMX)

In the same paper where Pierre Sikivie described the solar-axion search, he as well conceived of an RF-cavity search for Milky Way halo axions. The technique is to thread a high-Q microwave cavity with a large static magnetic field. Nearby halo axions scatter of the field and thereby convert into microwave photons. The resulting photon energy is that of the total energy of the axion. The microwave photons are detected in what is in essence an ultra low noise double-heterodyne radio receiver. The resonant frequency of the cavity is tunable across a search bandwidth. At each cavity tuning setting, the cavity power is averaged until the putative signal-to-noise ratio exceeds a threshold for realistic axions, and the power spectrum examined for excess power. The cavity is then re-tuned and search repeated until the cavity tuning range is exhausted. A schematic of ADMX realization of this[3] is shown in figure 3. The sensitivity of the technique is very good since the small axion-to-two-photon coupling appears only once, at the axion-to-photon conversion step in the cavity. Other techniques, not relying in already present axions, must as well produce those axions, which necessitates another factor of the very small, e.g., axion-to-two-photon coupling. The main challenge of the RF-cavity technique is that the expected microwave signal is very small, around 10^{-22} watts or less. Detecting such small electromagnetic RF power levels requires liquid helium temperatures to reduce the cavity blackbody photon backgrounds and electronic noise.

Low-noise microwave amplification is the key technology of this search. Early versions of ADMX used cryogenic field-effect-transistor (FET) amplifiers of modified radio telescope design, having noise temperatures in the neighborhood of 2K. The latest phase of this experiment replaces the FET amplifiers with dc SQUID amplifiers. These devices, when cooled with a dilution refrigerator, have noise temperatures near the quantum limit, approximately 50 mK at signal frequencies near 1 GHz. The averaging time it takes to achieve a certain signal-to-noise ratio depends on the square of the noise power. Hence, the reduction in noise from 2 K to 50 mK in replacing transistor amplifiers by SQUIDs yields a potential speed-up of over 1000. In practice, some of this gain will be used to improve sensitivity rather than simply speed up the search. Figure 1 shows the early ADMX results with transistor amplifiers ("Microwave Cavity" limits to the far left). Notice this is the only technique with sensitivity to realistic dark matter axion masses and couplings. Recently, ADMX announced limits from the experiment retrofitted with SQUID amplifiers and will shortly retrofit their instrument with a dilution refrigerator to reach near quantum-limited low-noise operation.

6. Summary and outlook

This overview only barely touched on dark-matter axion detection. I would be remiss without mentioning the axion model uncertainties. Although the calculation of the axion-to-two-photon coupling is claimed to be robust, there could be surprises. Also, precise mass limits at the extremes of the search range are not well known. Surprises could lurk there, as well. It's therefore prudent to

search for axions with “unusual” couplings and masses. Finally, this very short discussion necessarily left out many important searches and developments, for which I apologize. Perhaps the main result is that sensitivity to dark-matter QCD axions has at last been achieved with the RF cavity technique, and we may know soon whether the dark matter is made of axions

Acknowledgments

I thank the generous support of the U.S. Department of Energy, Office of High Energy Physics, for sponsoring this research under contract number DE-FG02-96ER40956.

References

- [1] Particle Data Group C.Amsler et al., Phys.Lett. B667 (2008) 459, “Axions and other very light bosons”.
- [2] K.Zioutas et al., Phys.Rev.Lett. 94 (2005) 121301.
- [3] S.Asztalos et al., Phys.Rev. D64 (2003) 092003.
- [4] S. Asztalos et al., Ann.Rev.Nucl.Part.Sci. 56 (2006) 293.

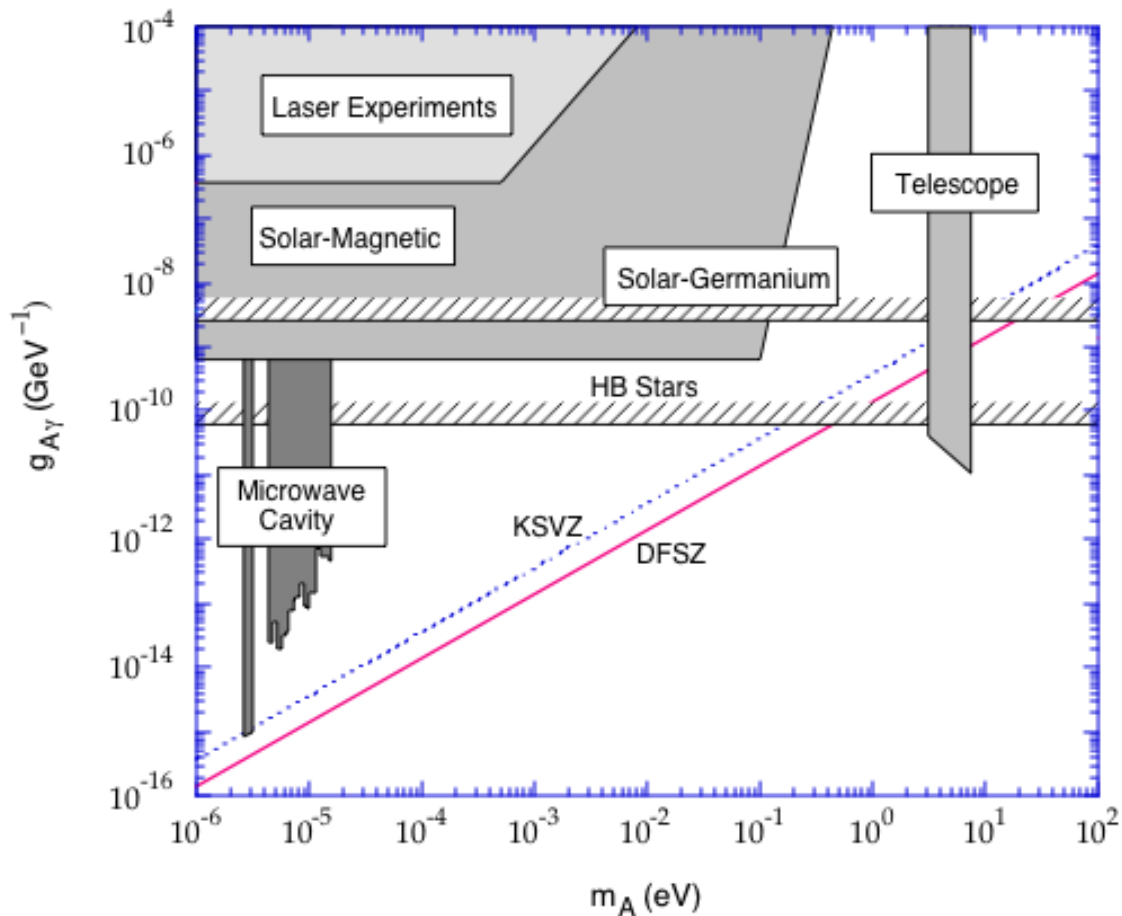

Figure 1. Selected limits on axion masses and couplings from a variety of techniques. The horizontal axis is the putative axion mass. The vertical axis is the effective coupling of the axion to two photons. “KSVZ” and “DSVZ” refer to two classes of axion models commonly targeted by searches. Dark-matter axions lie between the “KSVZ” and “DFSZ” models in the mass range 1-100 μeV . Not shown is the very restrictive upper bound to the coupling from sn1987a, which is a

horizontal line around a coupling of $10^{-13}/\text{GeV}$. (Figure from reference [4].)

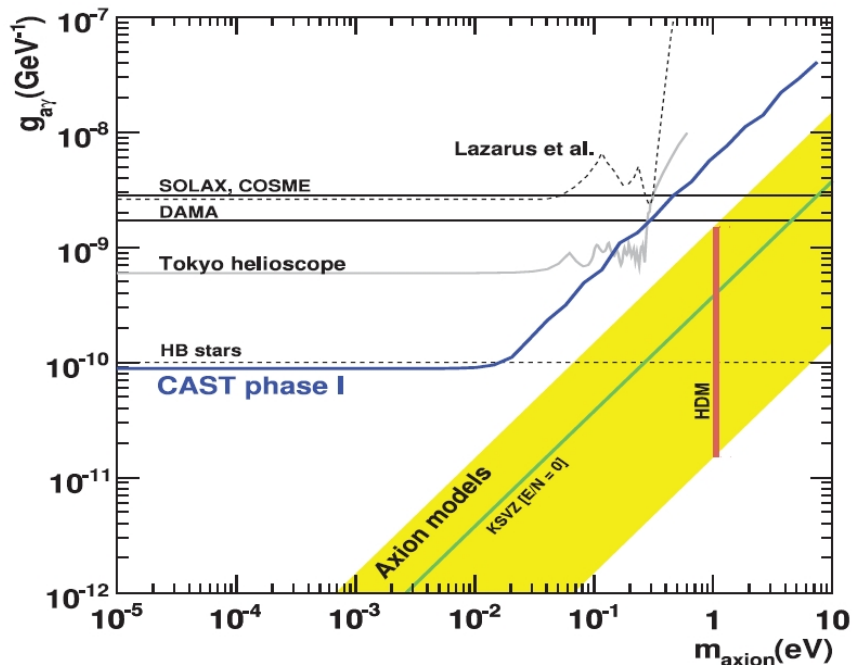

Figure 2. Limits from CAST Phase I operations (“CAST phase I”). The horizontal and vertical axes are those of figure 1. Note the CAST sensitivity in this phase is comparable to the astrophysical bounds (“HB stars”). The limit “Tokyo helioscope” are earlier results from a Japanese solar-axion search; this project has recently returned to data-taking. “SOLAX, COSME” and “DAMA” are limits from solar-axion searches using axion-to-photon conversion in a crystal. “Lazarus et al.” are limits from axion effects on propagation of laser light. (Figure from ref. [2])

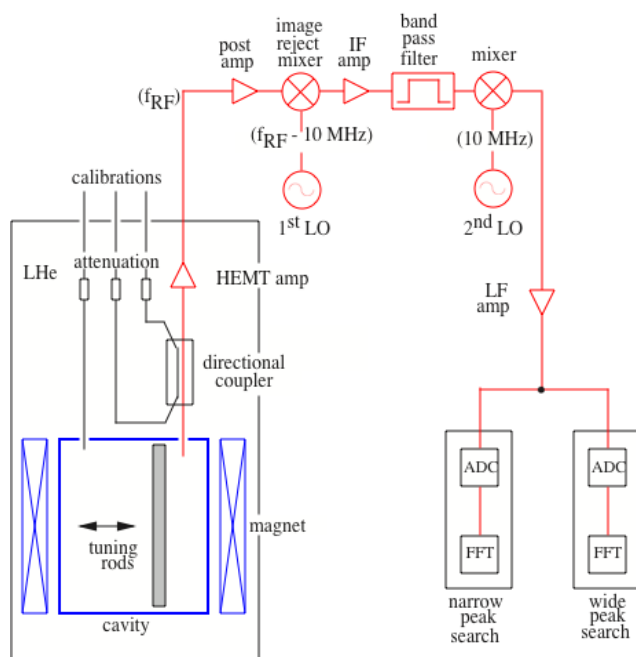

Figure 3. Schematic of the ADMX axion detector. The RF cavity, 0.5 m diameter by 1.0 m long, is in the bore of an 8.5 tesla solenoid magnet. Microwave power is amplified by a low-noise cryogenic amplifier and mixed-down to near audio. The result is digitized and processed with FFT electronics and the power spectrum is searched for axion signals. Two frequency resolutions, wide and narrow, are optimized for thermalized or non-thermalized (respectively) axions in our Milky Way halo.