

DEVELOPMENT OF A 14.5 – 18.0 GHz ECR ION SOURCE AT THE UNIVERSITY OF HUELVA*

Ismael Martel[#], Cristian Bontoiu, Maria José Ruiz Pomares, University of Huelva, Spain
 Alberto Garbayo, AVS, Elgoibar, Gipuzkoa, Spain
 Antonio C.C. Villari, Facility for Rare Isotope Beams, MSU, Michigan, U.S.A.

Abstract

A double frequency Electron Cyclotron Resonance Ion Source for the project LINCE (Linear European Center) in Huelva, Spain, is being designed for efficient production of high intensity ions from proton to Uranium. The magnetic design was optimized using three solenoid structures for axial and a dodecapole for radial confinement. Mechanical design studies were also initiated.

INTRODUCTION

The project LINCE (Linac European Centre) [1] in the University of Huelva aims developing a new high intensity low energy linear accelerator within the ECOS (European Collaboration on High Intensity Stable Beams) collaboration specifications [2]. The required intensities are of about 1mA for protons and from 10µA to 100 µA for heavy ions with a maximum mass over charge ration of 7. These intensities are achievable using present Electron Cyclotron Resonance Ion Source (ECRIS) technology at a maximum frequency of 18 GHz.

ECRIS are very reliable, high efficient and easy tuning ion sources, providing full compatibility with the specifications of the LINCE project. In particular, high efficiency is a very important feature for the production of multi-charged ions of isotopes with low natural abundance, like ⁴⁸Ca or ³⁶S.

The Linac facility studied for the University of Huelva aims to be used as well as for fundamental science as well as for industrial applications. In this sense, the facility should provide beams which are:

- Reliable: with possibility to run >6000 hours per year in 24/7 shifts
- Easy to tune: including automatic tuning of the beam
- High intensity: maximum beam intensity of 1 mA for light ions and 10µA for heavy ions

Selected beams and intensities required for both applications are listed in Table 1.

MAIN PARAMETERS

As shown in Table 1, the beam intensities and charge states are somehow conservative for ECRIS. Therefore the performance requested for the source does not correspond to maximum available intensities of 28 GHz

ECRIS. However, the running conditions of the LINCE project require high reliability, stability and easy tuning. These three requirements are only fulfilled if the ECRIS is *not* running close to its maximum performance.

Table 1: Beam Intensity Requirements in TARGET. Ion source intensities to be considered in the design correspond to the double of the listed in the table. Q correspond to the charge state of the ion and the intensities are in particle micro-Ampere.

Ion	Q	Intensity (µA)
H	1	1000
⁴ He	2	500
²⁸ Si	9	10
⁴⁸ Ca	8	10
¹⁸⁴ W	27	1
²³⁸ U	34	0.5

The development of the LINCE ECRIS are based on the Geller's scaling laws [3]:

$$I \propto n_e \propto \omega^2$$

$$\tau_{ion} \propto \frac{B_{max}}{B_{min}} \tag{1}$$

where I is the beam intensity, n_e is the electron density, ω is the heating frequency, τ_{ion} is the ion lifetime, and B_{max}/B_{min} is the ratio between the magnetic maximum and minimum fields in the mirror. We have chosen a source volume, magnetic field and frequency compatible with an electron temperature of 2 keV, corresponding to a plasma density by the ion lifetime of the order of 10^{11} s.cm⁻³, ensuring for example, efficient production of fully stripped $Z = 14$ (Si) ions.

The main parameters of the ECRIS are listed in the Table 2.

This can be considered as a middle-size ECRIS. The double frequency 14.5 GHz – 18.0 GHz is an important feature, providing tuning flexibility for a wide charge states range as well as for suppressing X-rays from the plasma [4] The ion source is fully superconducting and its design involves a dodecapole (for radial magnetic field)

*Work partially supported by the Spanish Government (MINECO-CDTI) under program FEDER INTERCONNECTA
 # imartel@uhu.es

placed outside the solenoids (axial magnetic field). The choice of Superconducting coils is firstly due to the fact that the source will be placed in a High Voltage Platform (H-V) up to 250 kV. Secondly, the variety of beams and versatility required excludes the use of permanent magnets. Finally, Nb-Ti wires are reliable and cost effective.

Table 2: Main Parameters of the LINCE ECRIS.

Parameter	Value
Frequencies	14.5 GHz – 18.0 GHz
RF power	1.0 kW (14.5 GHz) and 2.0 kW (18.0 GHz)
B_{\max} -injection	2.5 T
B_{\max} -extraction	1.4 T
B_{\max} -radial in the wall	1.4 T
Injection-extraction coil distance	336 mm

The use of a dodecapole (instead of hexapole) is already proven to be very effective [5], even providing slightly better beam properties. The choice of an external radial magnetic structure is two-fold. First, the clamping of the magnetic structure is facilitated as in the SECRAL configuration [6] and second, the length of the multipole is limited to the plasma region, keeping the extraction region with a smaller magnetic radial field when compared to the inverse configuration. The axial field is provided by three coils, being the central one used to “tune” the minimum B of the source.

The performance of the source is expected to be similar to the known SERSE [7], and slightly better than GTS [8] and PKISIS [9], which have similar sizes and magnetic fields.

OVERALL DESIGN

Special care was taken in designing the radio-protection of the source, which is as close as possible of the plasma chamber. This is of paramount importance for having minimum dose in the environment of the H-V platform as well as on the Superconducting coils. The chamber is, therefore, surrounded by 1 cm thick lead. Moreover, important space is also reserved for the super-insulator, and separated vacuum for the cryostat. The coils are also electrically insulated from the cryostat by 5 mm thick virgin polypropylene, allowing the chamber to be at 30 kV from the extraction electrode.

The coils are supported by an aluminium structure, which is supported by fiberglass inside the cryostat. The design of the thermal insulation and details of the He circuit will be done in a later stage of the work. The source is surrounded by an Iron structure closing the magnetic circuit.

Figure 1 shows the overall design of the interior of the source. The injection side has two RF injections, one axial sputtering facility and off-axis entrance for an oven.

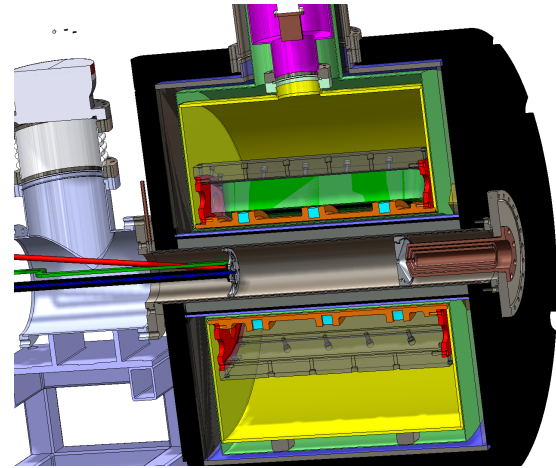

Figure 1: Opened picture of the LINCE ECRIS.

The gas injection is also done in the injection side. The bias disk is placed separated from the RF coupling flange. The final flange of the chamber is movable for precisely tuning the length of the chamber, which is needed in beginning of operation. The position of this flange can be fixed after the first tuning [8].

The pumping of the injection is ensured by a 500 l/s turbo pump in the version shown in the drawing, however a 300 l/s can be used instead. Magnetic protection has to be included in the turbo pump (not shown).

The extraction of the source has a tetrode structure including the plasma electrode, a first puller and two extra electrodes for stopping electrons coming from the beam line. Our previous experience with ECR ion sources have shown that electrons produced after the extraction can deteriorate the performance of the source. This is the case mainly for sources without a solenoid as first optical element, like the one of LINCE. The first optical element of the beam line is an Einzel lens. The Einzel lens was preferred from Solenoids for providing less aberrations and for decreasing significantly the power needed in the H-V platform. An exploded drawing of the source is shown in Figure 2.

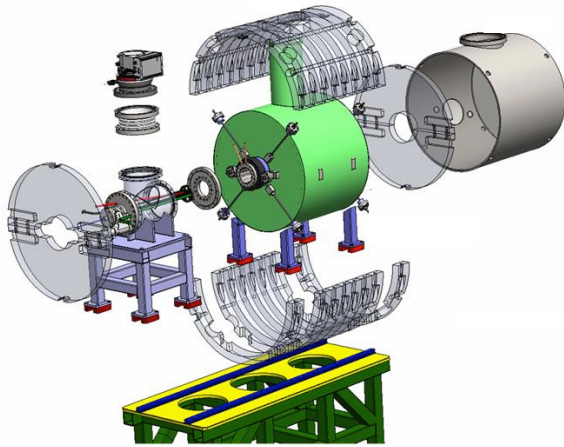

Figure 2: Exploded picture of the LINCE ECRIS.

MAGNETIC DESIGN

The design of the solenoids and of the dodecapole were carried out using the Comsol [10] ACDC module. This uses a stationary algorithm for solving the Ampere’s law for arbitrary meshed geometries material properties like magnetic permeability and electric conductivity.

The strategy in designing the solenoids, for example, followed the following steps:

- adjust the solenoids currents to reach the necessary on-axis injection, minimum and extraction fields
- find the most suitable axial distance between the solenoids such that the resonance region (distance between the closest injection and extraction on-axis field slopes at B_{ECR}) is maximized;
- study the influence of the solenoids length on the resonance region size and extend it even further;
- modify the solenoids shell thickness to reduce the risk of quench by lowering the design current density.

The design of the dodecapole followed a different strategy, which will be subject of a further publication.

The present design include 3 solenoid coils for axial magnetic field with 168 mm spacing and having 20 mm width and 25 mm length. The magnetic field for three different currents are shown in Figure 3. All combinations of the three curves are feasible, which means that the minimum B can correspond to the dotted line whilst the maximum injection magnetic field can correspond to the highest field. The radial magnetic field ($\frac{1}{2}$ distance) in the chamber wall is shown in Figure 4. It is interesting to note that the radial field in the extraction region (after 20 mm from the centre) is extremely low, which corresponds to the specifications and will provide excellent beam characteristics. The field is only maximized in a region slightly larger than the plasma confinement.

FUTURE DEVELOPMENT

Future development will concern the design of the clamping and the detailed design of the insulation of the coils. Moreover, some more studies will be made for increasing slightly the plasma region changing the distance between the main coils. Detailed studies of quenching conditions have still to be made. The polarization of a single axial coil with or without powering the dodecapole, which is important for operation, should be studied.

CONCLUSION

The Superconducting LINCE Double Frequency ECRIS for production of high intensity light and heavy ion beams of medium high charge states was presented. The choice of 14.5 GHz and 18.0 GHz fixed the magnetic field in axial and radial according to Geller’s rules. The use of standard technology in an innovative combination allows to have a reliable whilst cost effective ion source with the desired characteristics.

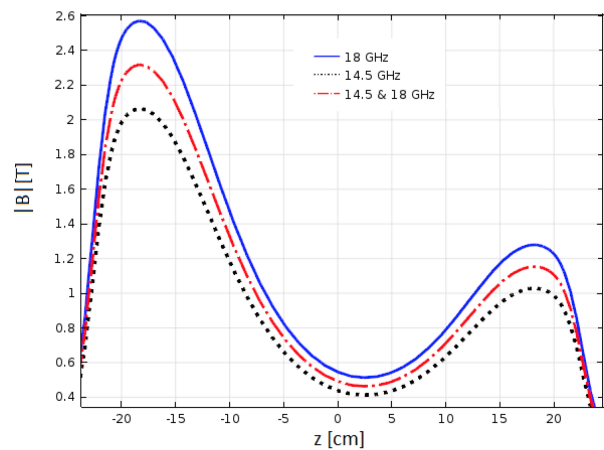

Figure 3: Axial magnetic profile of the LINCE ECRIS.

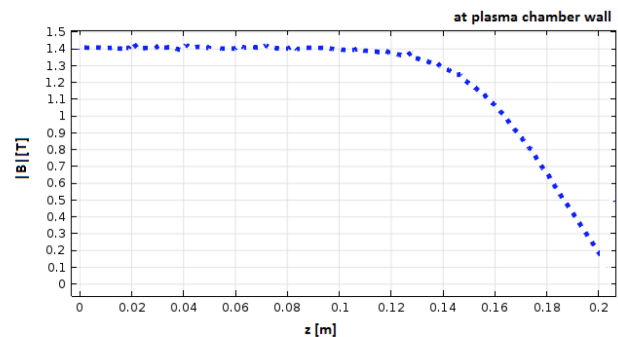

Figure 4: Radial magnetic profile of the LINCE ECRIS.

REFERENCES

- [1] I. Martel et al., "LINCE: A High Intensity Multi-ion Superconducting Linac for Nuclear Structure and Reactions", IPAC'14, Dresden, Germany, June 2014, THPME036, These Proceedings.
- [2] ECOS, <http://www.nupecc.org/ecos/ECOS-Final.pdf>
- [3] R. Geller, Ann. Rev. Nucl. Part. Sci. 40 (1990) 15
- [4] D. Leitner et al., Rev. Sci. Instr. 79 (2008) 033302
- [5] P. Sortais et al, Nanogan, An ultra-compact ECRIS for on-line and high voltage applications, XI ECRIS, Groningen 1993.
- [6] L.T. Sun, et al., Journ. Phys. Conf. Series 58 (2007) 435
- [7] G. Ciavola, et al., Frequency upgrading of the Superconducting ECR Ion Source SERSE, Proc. PAC (1999) 97
- [8] D. Hits, et al., A New Room temperature ECR ion source for accelerator facilities, Proceedings EPAC (2002) 1718
- [9] G. Gaubert, et al., Rev. Sci. Instr. 83 (2012) 02A344
- [10] <http://www.comsol.com/products/multiphysics/>